

# HeighTivity

Original

353630.0

EN - Assembly Instruction and User Manual (Page 2)

US - Assembly Instruction and User Manual (Page 9)

DE - Montageanleitung (Seite 16)

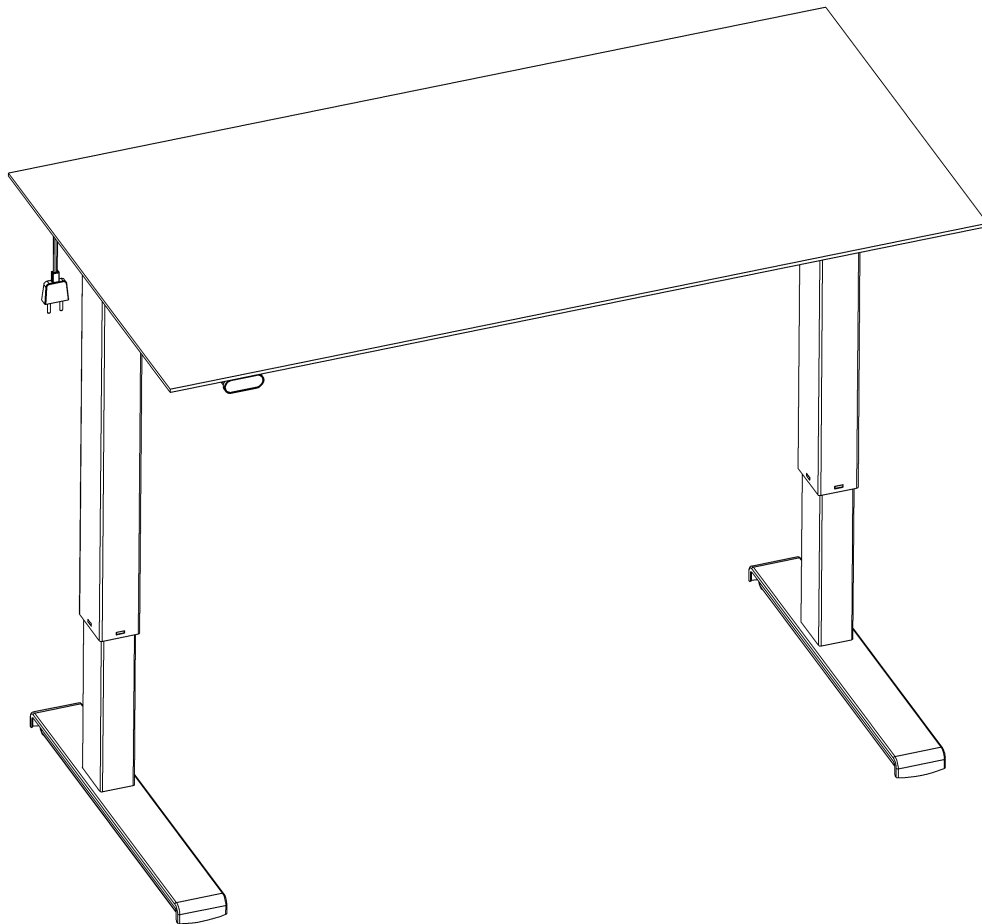

## TABLE OF CONTENTS

1. Safety and warnings
2. Usage
3. Set up and installation
4. Operation
5. Maintenance and defects
6. Technical data
7. Parts
8. Assembly instructions
9. Declaration of conformity

## IMPORTANT NOTES!

Prior to installment, use and maintenance of the table frame, any installer and any user of the table must study this assembly and operation manual carefully, so as to gain a complete understanding of its contents

### 1. Safety and warnings

This table complies with the prescribed safety regulations. Inappropriate use may cause damage to persons and table.

Please read the operation manual prior to start using the table. It provides you with important information about safety, use, installation and maintenance of the table, and thus protecting you and your children and avoiding damage on the table.

Please guard this operation manual and pass it on to any future owner!

### 2. Usage

The electromotive, height-adjustable tables are designed for workstations in dry work environments only (0-40°C; 20-90% relative humidity). The table height is infinitely adjustable, so that it can be set to the most ergonomically suitable working level:

- They have not been designed for other purposes than those included in this manual, e.g. they are not to be used in areas of high humidity or dampness, nor for lifting people. Any other use is at one's own risk!
- Do not crawl, lie or move around under the table frame, and do not sit or stand on the table frame.
- CHILDREN should only use the table when supervised by adults.
- Liability - The manufacturer accepts under no circumstances warranty claims or liability claims for damages arising from improper use or handling of the table frame other than that described in this operation manual.

### 3. Set up and installation

- When the table has been assembled (see assembly instructions in CHAPTER 8) the adjustable feet are installed so that the table is level and does not shift. Then the table is connected to the 100-240 VAC outlet and the table is ready for use.
- Make sure that no cables can get jammed.
- Place the table in a safe distance from window frames, radiators, furniture etc. so that people do not get stuck.
- Do not place any objects above 21" (55 cm) underneath the table.
- When moving the table after it has been assembled, the tabletop needs to be removed. The table CANNOT be lifted by the tabletop. The desk need to be lowered to minimum height before moving.

### 4. Operation

UP/DOWN operation:

Push the buttons for operation up or down

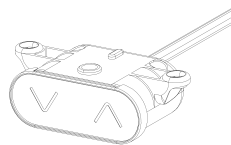

WARNING: FAILURE TO COMPLY WITH OR OBSERVE ALL ASSEMBLY, SAFETY AND OPERATION INSTRUCTIONS AND WARNINGS REGARDING THE USE OF THIS PRODUCT MAY RESULT IN SERIOUS BODILY INJURY.

## 5. Maintenance and defects

- The table does not require any maintenance by usage as described in chapter 2 in the directions for use.
- The table is only to be maintained with a damp cloth
- In the event of the occurrence of jarring sounds during operation, STOP using the table and please contact the dealer.

## 6. Technical data

<b>Frame, materials</b>	Steel, powder lacquered
<b>Weight</b>	17kg (frame only)
<b>Width</b>	Up to 180cm
<b>Depth</b>	Up to 80cm
<b>Height</b>	68 - 118cm
<b>Max. load</b>	50kg on tabletop
<b>Speed</b>	25 mm/sec
<b>Duty cycle</b>	10% by 50% of max. load on frame or max. 2 min. continuously
<b>Operation</b>	Micro switches
<b>Voltage</b>	100-240 VAC   50/60 Hz
<b>Standby Consumption</b>	< 0,15 Watt

## 7. Parts

See page 4.

## 8. Assembly instructions

See page 5 - 8.

## 9. Declaration of conformity

We hereby declare, under our sole responsibility that the following products:

- Sit and stand table product type HeighTivity

is in accordance with:

- Directive 2006/42/EF of The European Parliament and of the Council of 17 May 2006 on machinery

With reference to the above please be aware that:

- the sit and stand table is considered a machine and
- the sit and stand table may not be used until it has been assembled and installed according to the instructions.

## Manufacturer

HeighTivity by ConSet A/S | Industrivej 23 | 6900 Skjern | Denmark  
www.heightivity.com | Tlf.: +45 96800080 | info@heightivity.com

## 7. Parts

Ⓐ Center travers

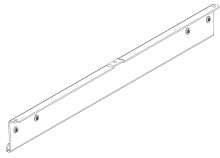

x1

Ⓑ Side travers

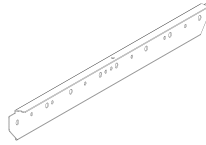

x2

Ⓒ Center tube

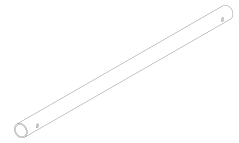

x1

Ⓓ Non-motor leg tube

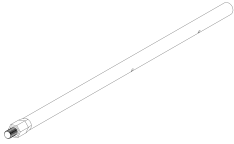

x1

Ⓔ Motor leg tube

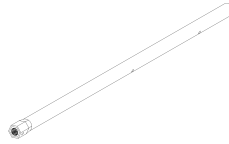

x1

Ⓕ Motor leg

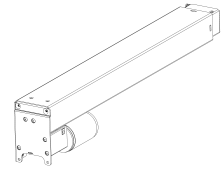

x1

Ⓖ Non-motor leg

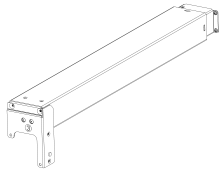

x1

Ⓗ Tabletop bracket L

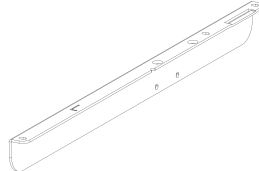

x1

Ⓘ Tabletop bracket R

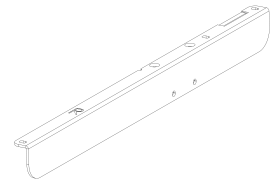

x1

Ⓙ Foot

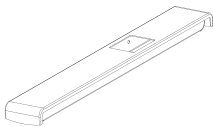

x2

Ⓚ M5x8mm

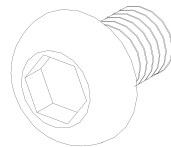

x28

Ⓛ M5x8mm

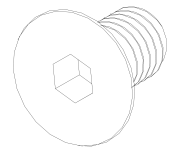

x4

Ⓜ Glide M6x20

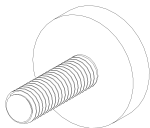

x4

Ⓝ Screw 5x16mm



x15

Ⓞ Screw 3x16mm

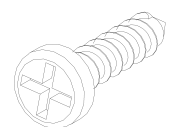

x2

Ⓟ Power supply

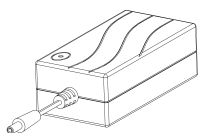

x1

Ⓠ Power supply bracket

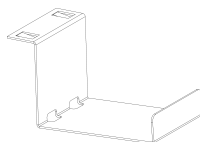

x1

Ⓡ Power cord

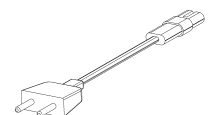

x1

Ⓢ Control panel

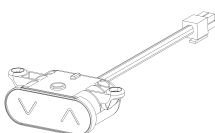

x1

Ⓣ Wirenail

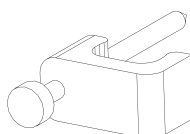

x2

## 8. Assembly Instruction and User Manual

### 1 Adjusting travers

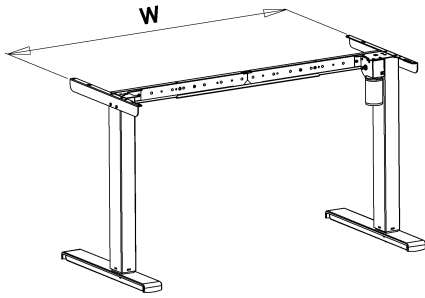

W, cm	W, inch		X, cm	X, inch
112cm	44 1/8"		111cm	43 3/4"
127cm	50"		126cm	49 5/8"
142cm	55 7/8"		141cm	55 1/2"

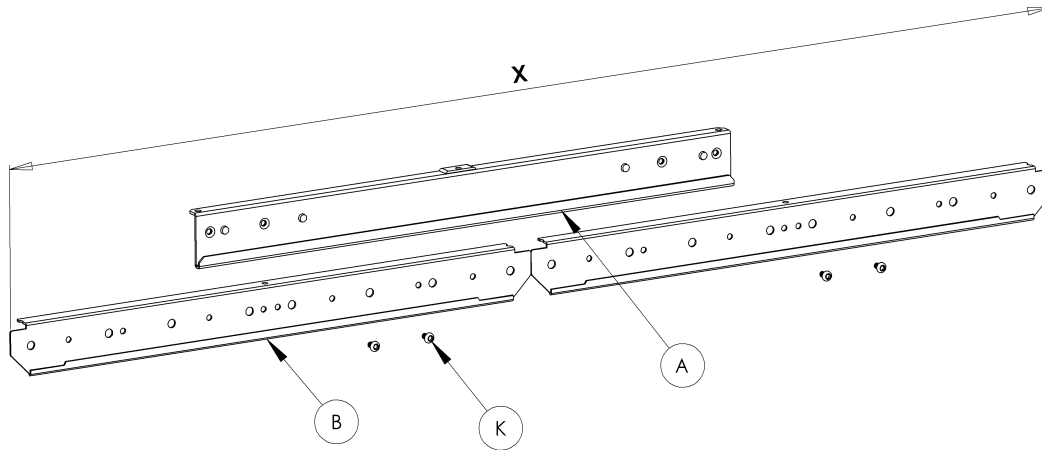

### 2 Adjusting carrier tube

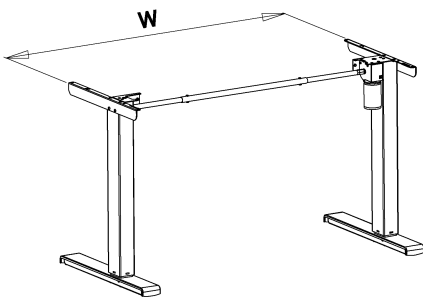

W, cm	W, inch		Y, cm	Y, inch
112cm	44 1/8"		97cm	38 1/4"
127cm	50"		112cm	44 1/8"
142cm	55 7/8"		127cm	50"

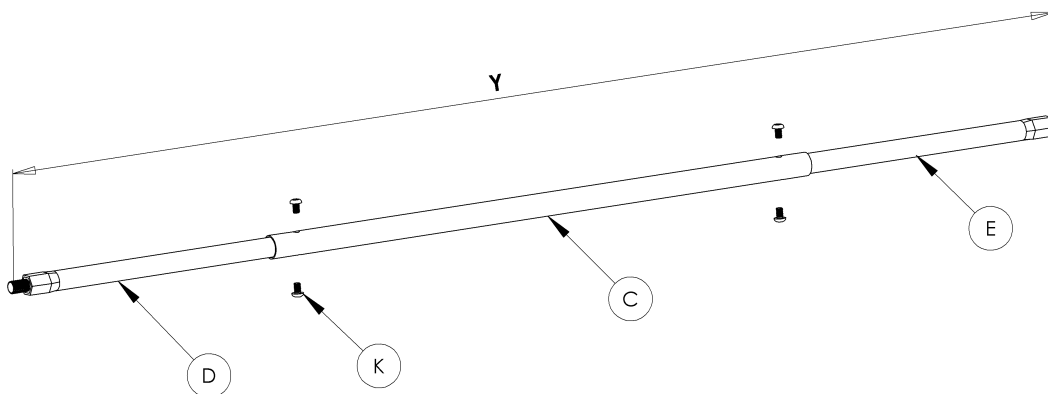
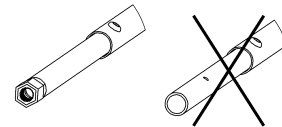

### 3 Mounting of topbrackets

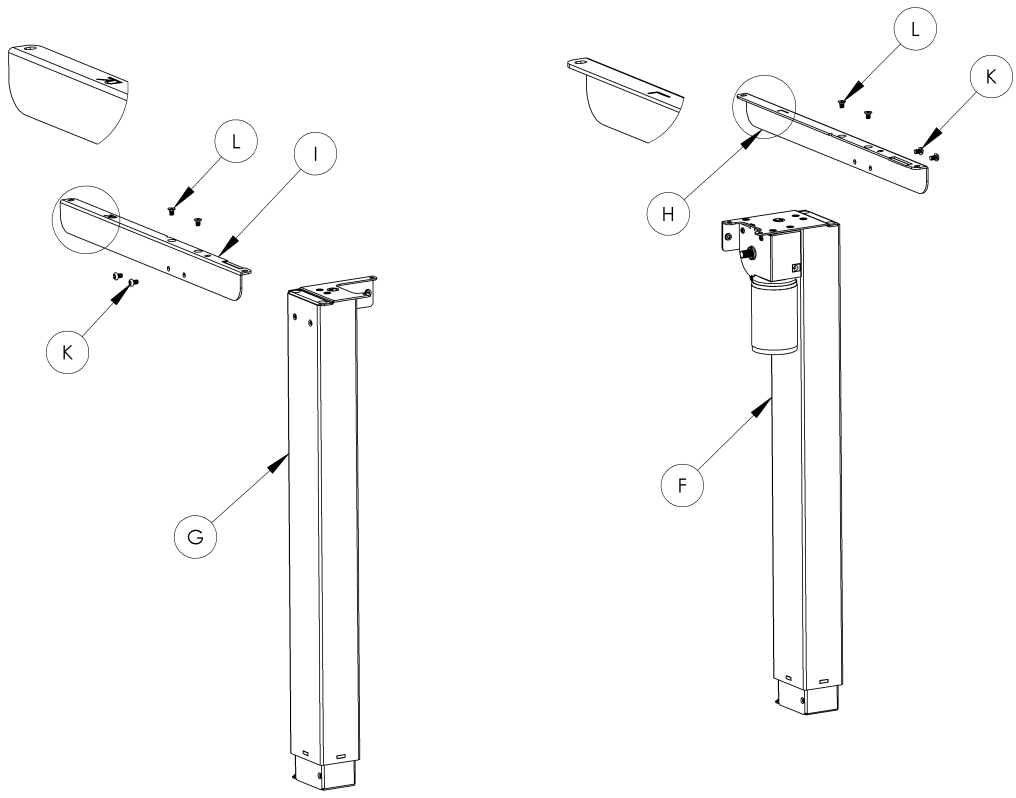

Attach top bracket marked "R" to the non-motor leg. Attach top bracket marked "L" to the motor Leg.

### 4 Mounting of Non-motor leg

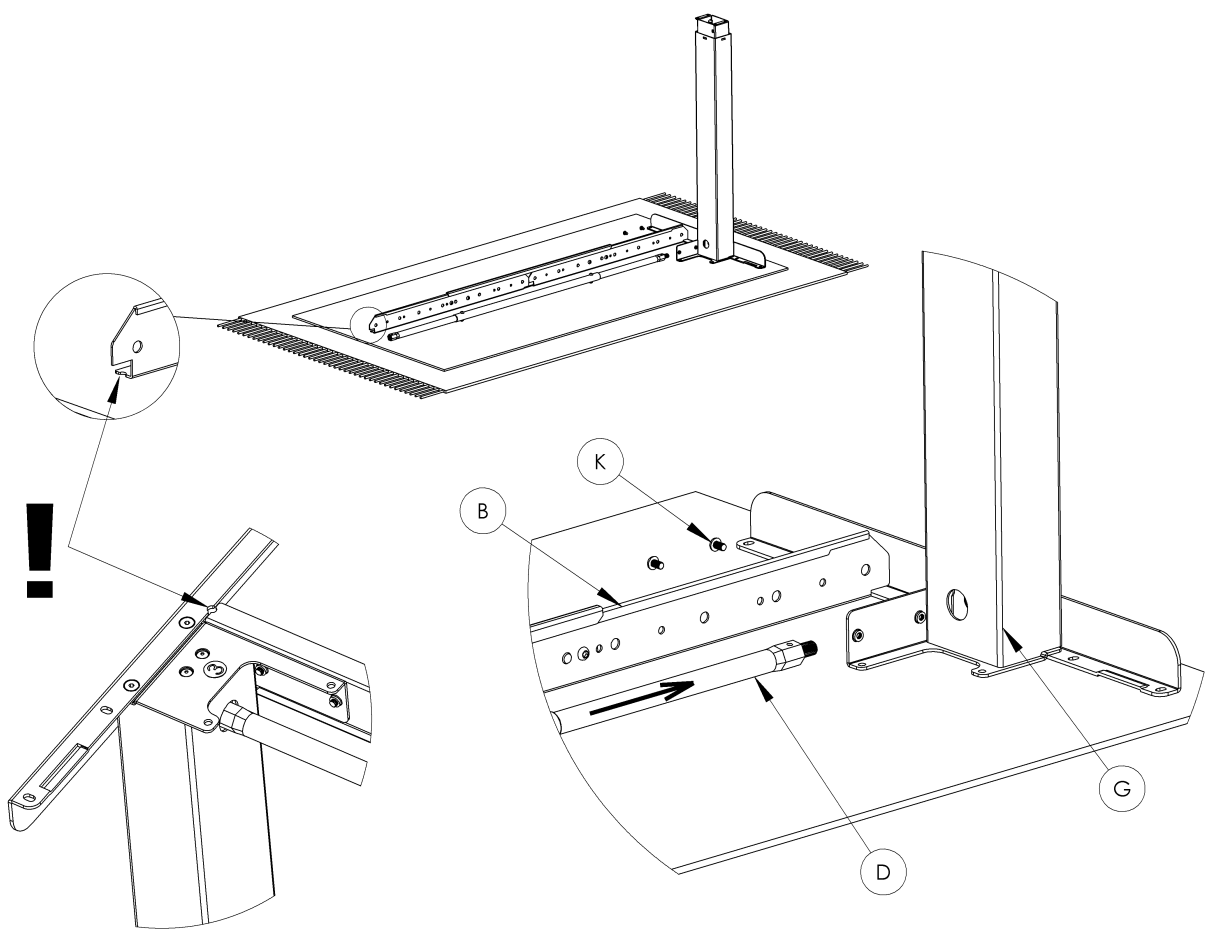

**5** Mounting of Motor leg

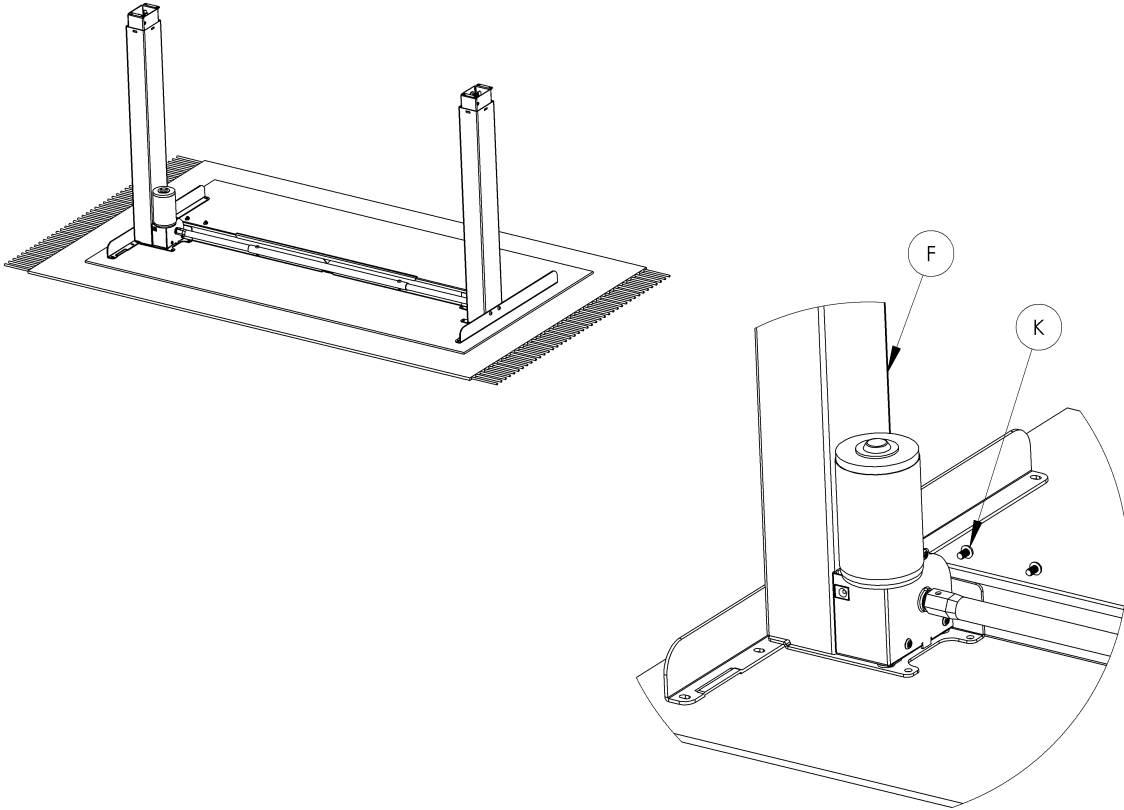

**6** Mounting of feet

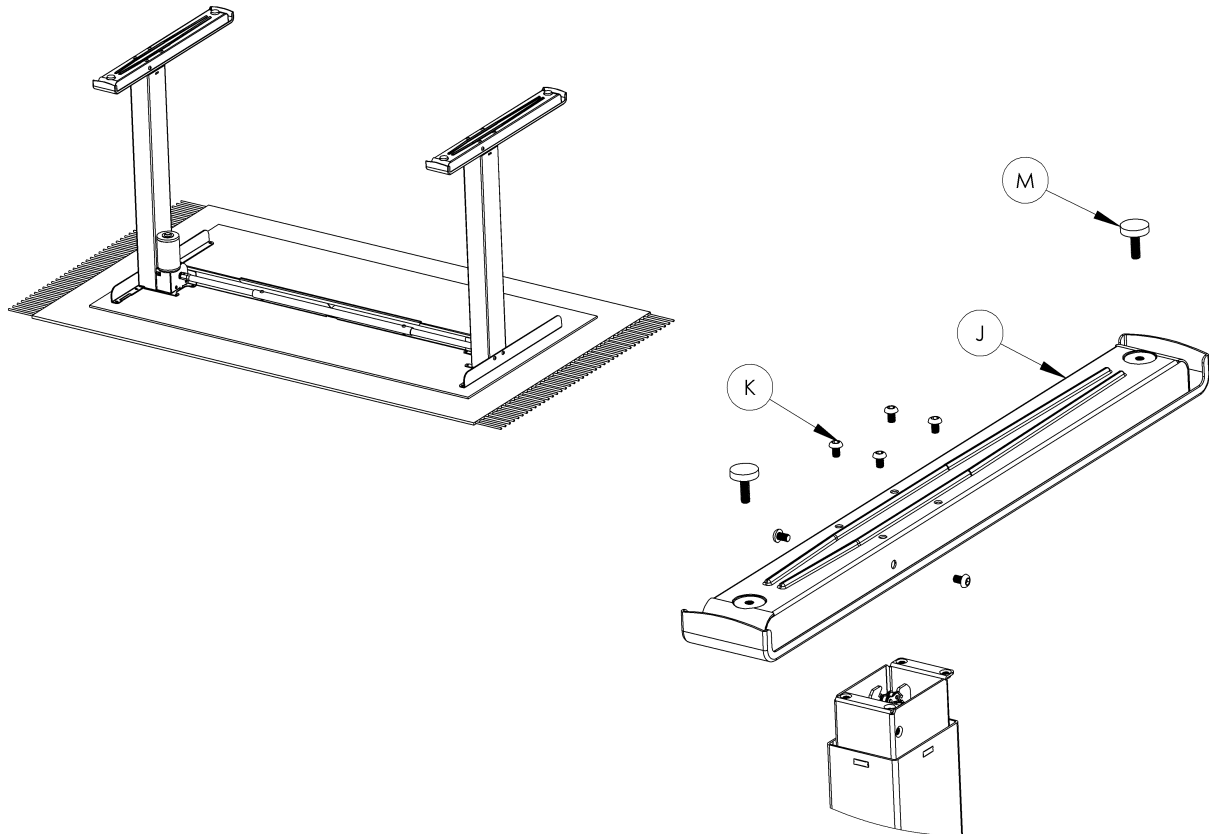

## 7 Mounting of tabletop

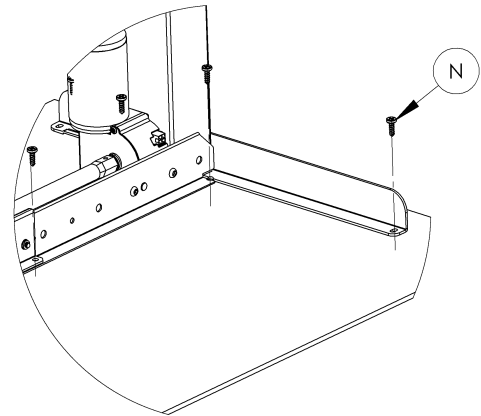
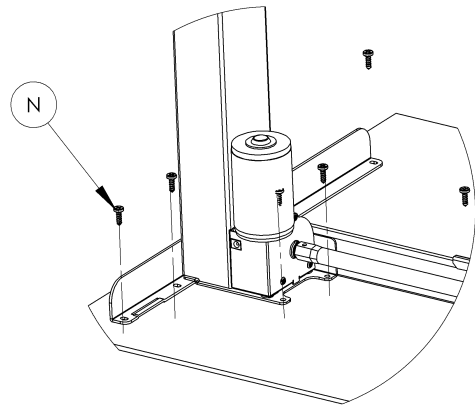
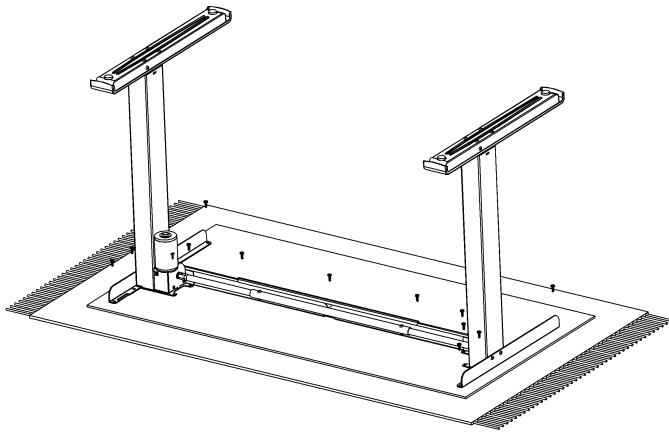

## 8 Mounting of power and control

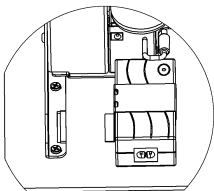
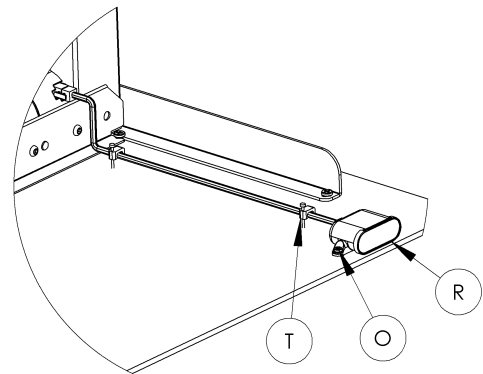
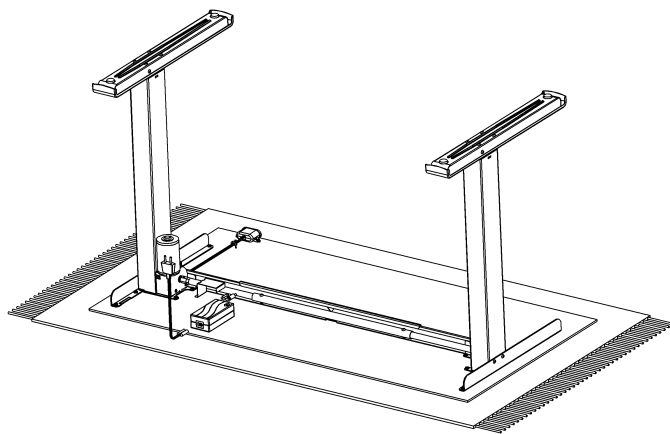

← *click*

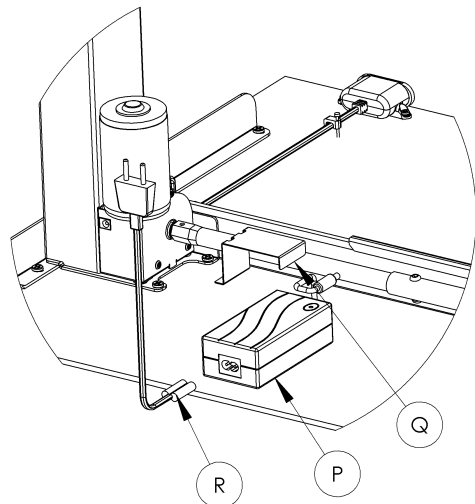
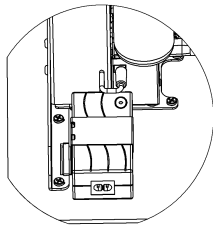
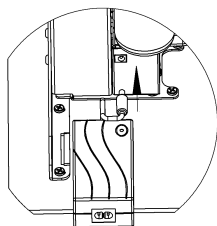



## TABLE OF CONTENTS

1. Safety and warnings
2. Usage
3. Set up and installation
4. Operation
5. Maintenance and defects
6. Technical data
7. Parts
8. Assembly instructions
9. Declaration of conformity

## IMPORTANT NOTES!

Prior to installment, use and maintenance of the table frame, any installer and any user of the table must study this assembly and operation manual carefully, so as to gain a complete understanding of its contents

### 1. Safety and warnings

This table complies with the prescribed safety regulations. Inappropriate use may cause damage to persons and table.

Please read the operation manual prior to start using the table. It provides you with important information about safety, use, installation and maintenance of the table, and thus protecting you and your children and avoiding damage on the table.

Please guard this operation manual and pass it on to any future owner!

### 2. Usage

The electromotive, height-adjustable tables are designed for workstations in dry work environments only (0-40°C; 20-90% relative humidity). The table height is infinitely adjustable, so that it can be set to the most ergonomically suitable working level:

- They have not been designed for other purposes than those included in this manual, e.g. they are not to be used in areas of high humidity or dampness, nor for lifting people. Any other use is at one's own risk!
- Do not crawl, lie or move around under the table frame, and do not sit or stand on the table frame.
- CHILDREN should only use the table when supervised by adults.
- Liability - The manufacturer accepts under no circumstances warranty claims or liability claims for damages arising from improper use or handling of the table frame other than that described in this operation manual.

### 3. Set up and installation

- When the table has been assembled (see assembly instructions in CHAPTER 8) the adjustable feet are installed so that the table is level and does not shift. Then the table is connected to the 100-240 VAC outlet and the table is ready for use.
- Make sure that no cables can get jammed.
- Place the table in a safe distance from window frames, radiators, furniture etc. so that people do not get stuck.
- Do not place any objects above 21" (55 cm) underneath the table.
- When moving the table after it has been assembled, the tabletop needs to be removed. The table CANNOT be lifted by the tabletop. The desk need to be lowered to minimum height before moving.

### 4. Operation

UP/DOWN operation:

Push the buttons for operation up or down

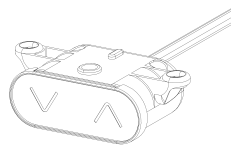

WARNING: FAILURE TO COMPLY WITH OR OBSERVE ALL ASSEMBLY, SAFETY AND OPERATION INSTRUCTIONS AND WARNINGS REGARDING THE USE OF THIS PRODUCT MAY RESULT IN SERIOUS BODILY INJURY.

## 5. Maintenance and defects

- The table does not require any maintenance by usage as described in chapter 2 in the directions for use.
- The table is only to be maintained with a damp cloth
- In the event of the occurrence of jarring sounds during operation, STOP using the table and please contact the dealer.

## 6. Technical data

<b>Frame, materials</b>	Steel, powder lacquered
<b>Weight</b>	38 lbs (frame only)
<b>Width</b>	59"
<b>Depth</b>	23 5/8"
<b>Height</b>	26 3/4" - 46 1/2"
<b>Max. load</b>	110 lbs on tabletop, uniform loaded
<b>Speed</b>	25 inch/sec
<b>Duty cycle</b>	10% by 50% of max. load on frame or max. 2 min. continuously
<b>Operation</b>	Micro switches
<b>Voltage</b>	100-240 VAC   50/60 Hz
<b>Standby Consumption</b>	< 0,15 Watt

## 7. Parts

See page 12.

## 8. Assembly instructions

See page 12 - 15.

## 9. Declaration of conformity

We hereby declare, under our sole responsibility that the following products:

- Sit and stand table product type HeighTivity

is in accordance with:

- Directive 2006/42/EF of The European Parliament and of the Council of 17 May 2006 on machinery

With reference to the above please be aware that:

- the sit and stand table is considered a machine and
- the sit and stand table may not be used until it has been assembled and installed according to the instructions.

## Manufacturer

HeighTivity by ConSet A/S | Industrivej 23 | 6900 Skjern | Denmark  
www.heightivity.com | Tlf.: +45 96800080 | info@heightivity.com

## 7. Parts

Ⓐ Center travers

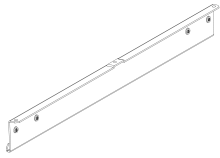

x1

Ⓑ Side travers

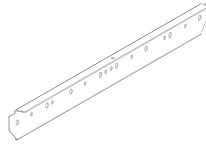

x2

Ⓒ Center tube

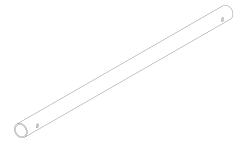

x1

Ⓓ Non-motor leg tube

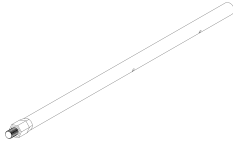

x1

Ⓔ Motor leg tube

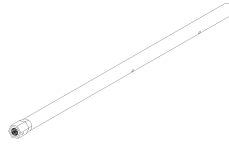

x1

Ⓕ Motor leg

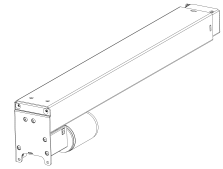

x1

Ⓖ Non-motor leg

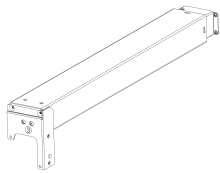

x1

Ⓗ Tabletop bracket L

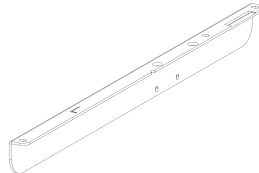

x1

Ⓘ Tabletop bracket R

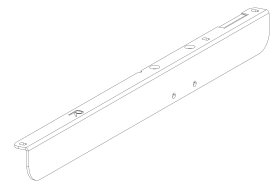

x1

Ⓙ Foot

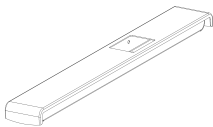

x2

Ⓚ M5x8mm

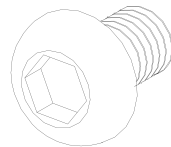

x28

Ⓛ M5x8mm

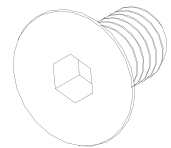

x4

Ⓜ Glide M6x20

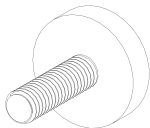

x4

Ⓝ Screw 5x16mm



x15

Ⓞ Screw 3x16mm

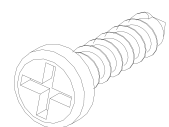

x2

Ⓟ Power supply

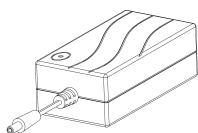

x1

Ⓠ Power supply bracket

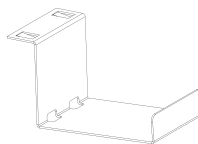

x1

Ⓡ Power cord

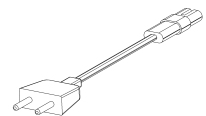

x1

Ⓢ Control panel

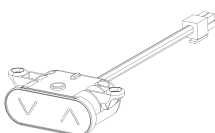

x1

Ⓣ Wirenail

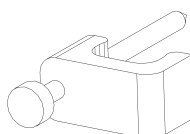

x2

## 8. Assembly Instruction and User Manual

### 1 Adjusting travers

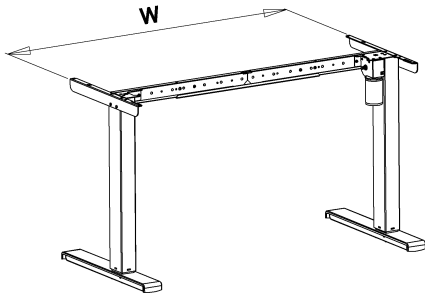

W, cm	W, inch		X, cm	X, inch
112cm	44 1/8"		111cm	43 3/4"
127cm	50"		126cm	49 5/8"
142cm	55 7/8"		141cm	55 1/2"

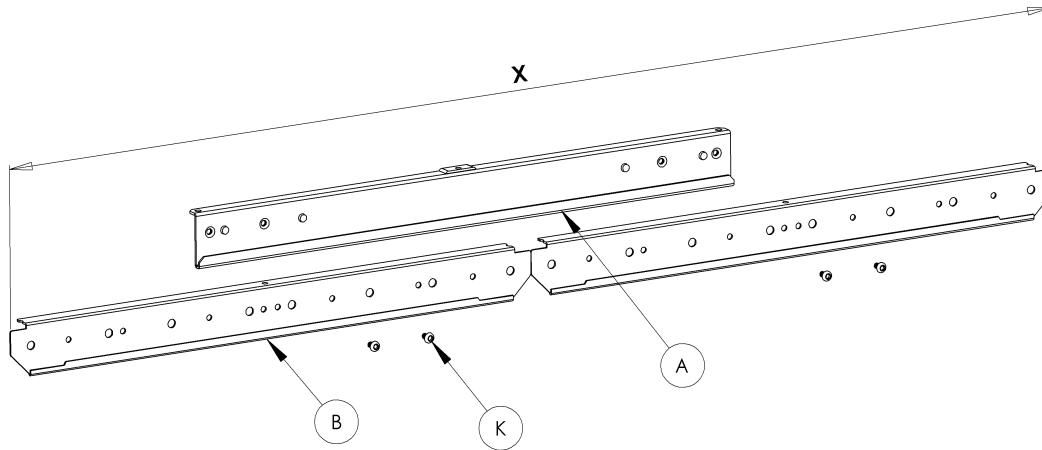

### 2 Adjusting carrier tube

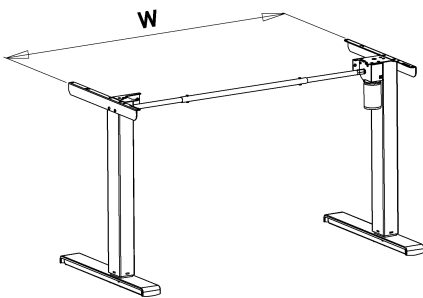

W, cm	W, inch		Y, cm	Y, inch
112cm	44 1/8"		97cm	38 1/4"
127cm	50"		112cm	44 1/8"
142cm	55 7/8"		127cm	50"

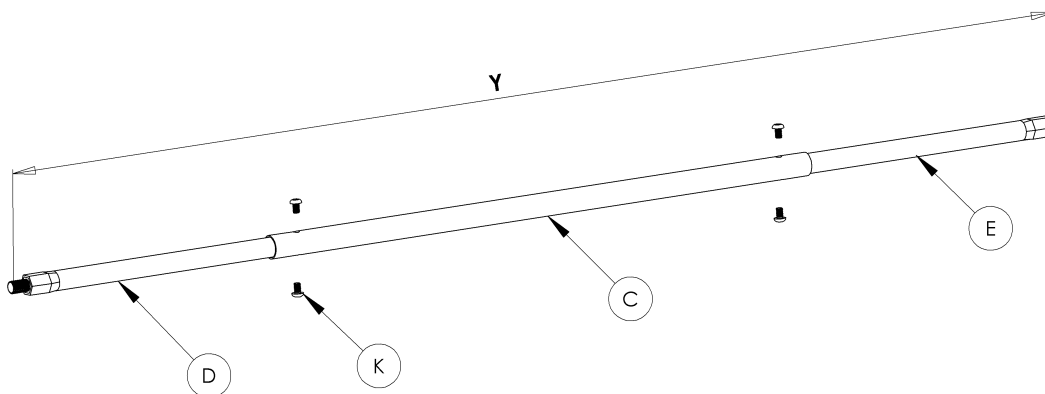
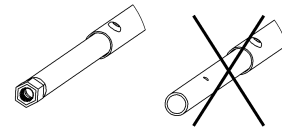

### 3 Mounting of topbrackets

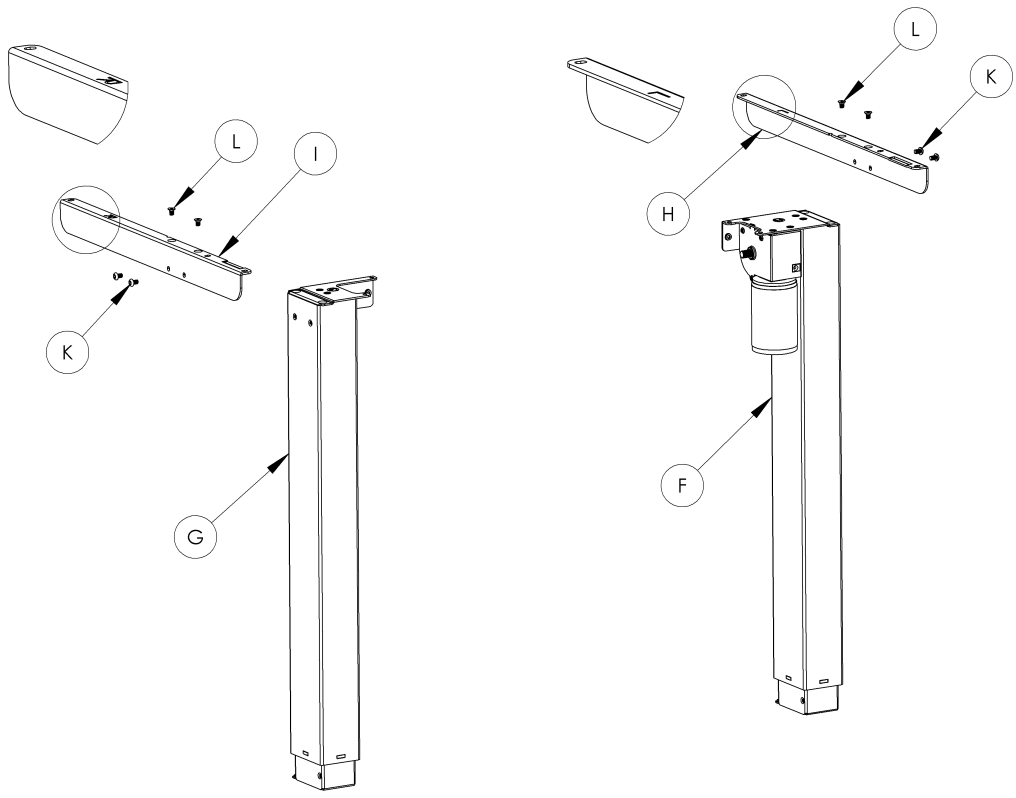

Attach top bracket marked "R" to the non-motor leg. Attach top bracket marked "L" to the motor Leg.

### 4 Mounting of Non-motor leg

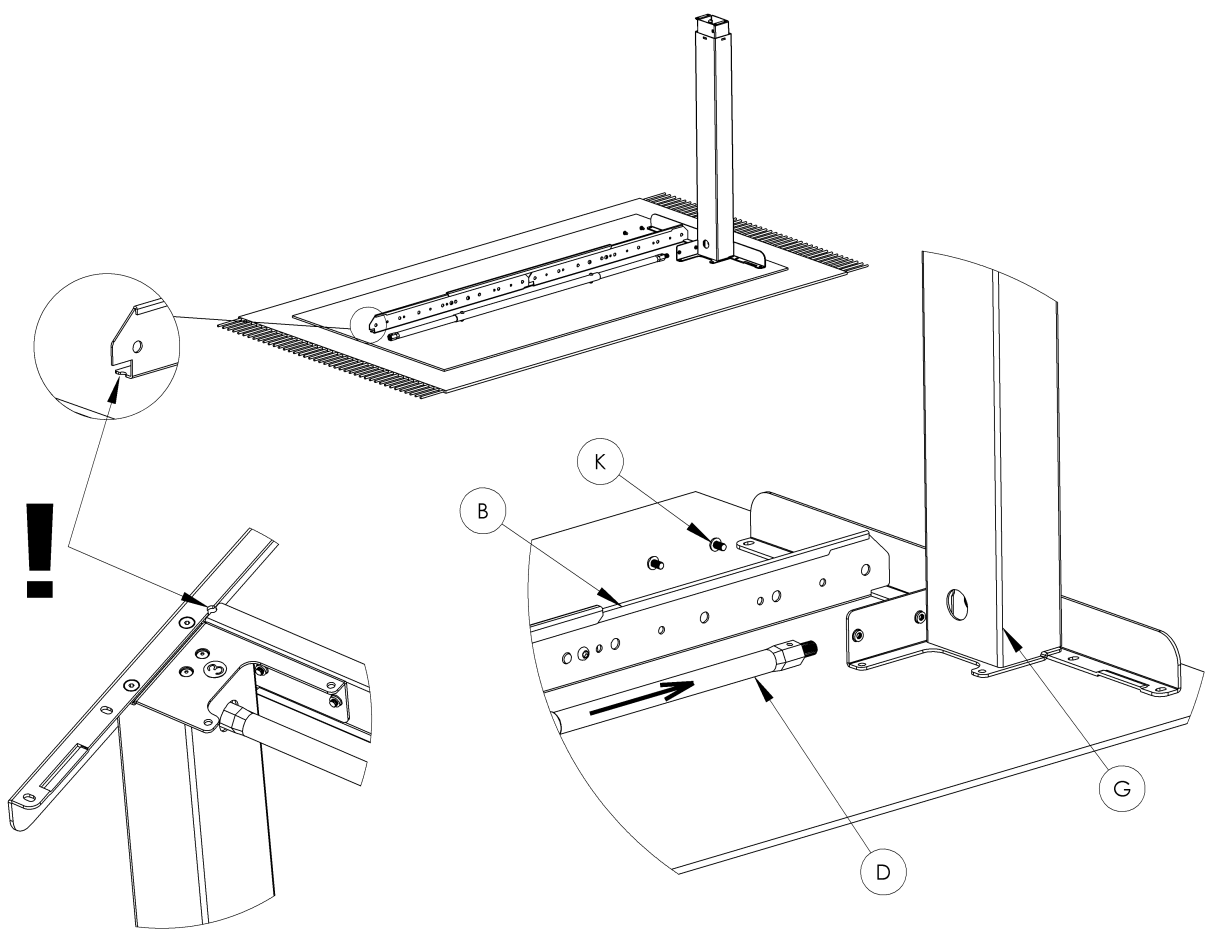

**5** Mounting of Motor leg

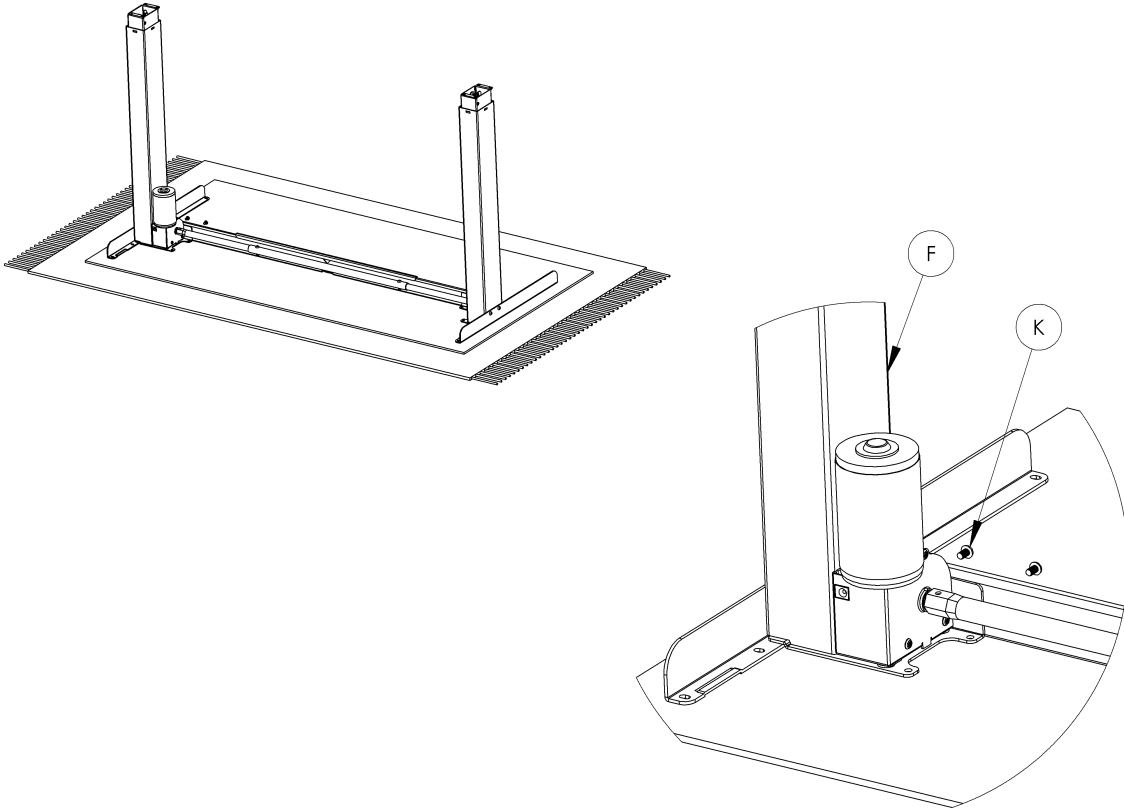

**6** Mounting of feet

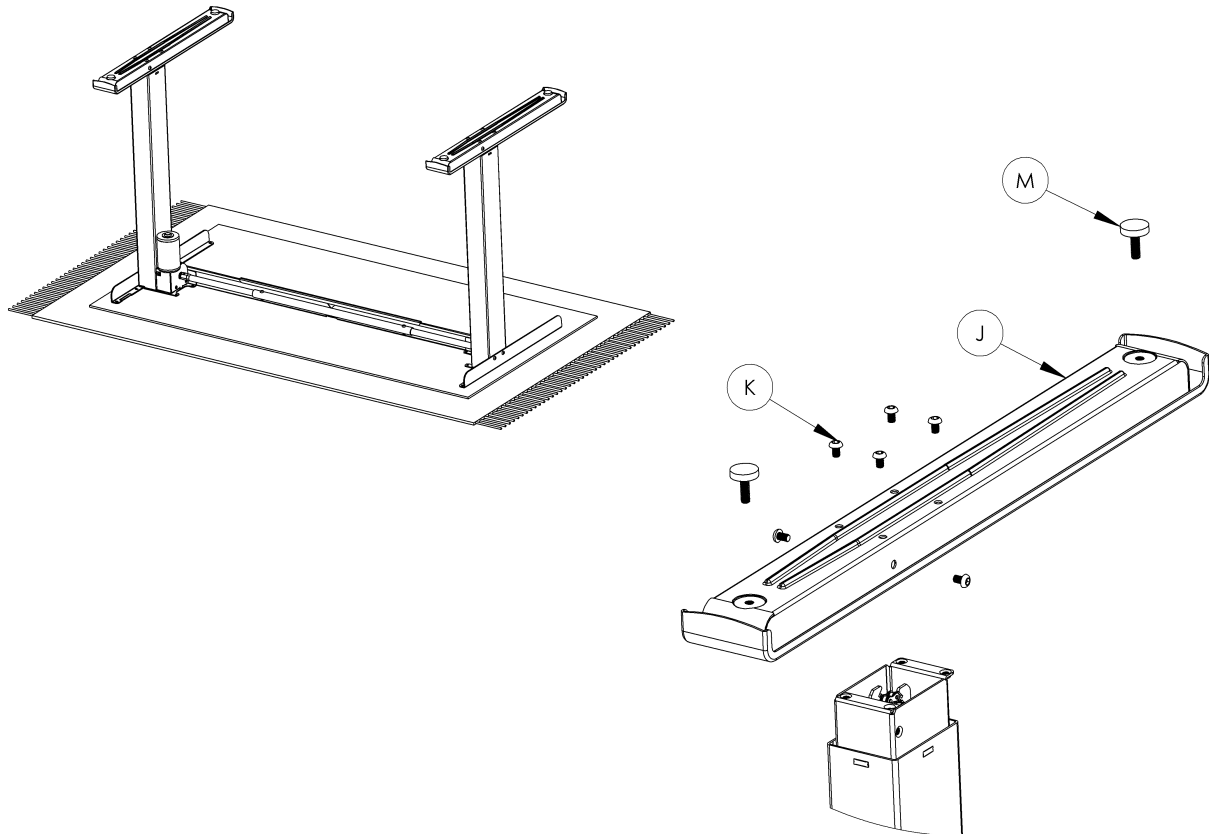

## 7 Mounting of tabletop

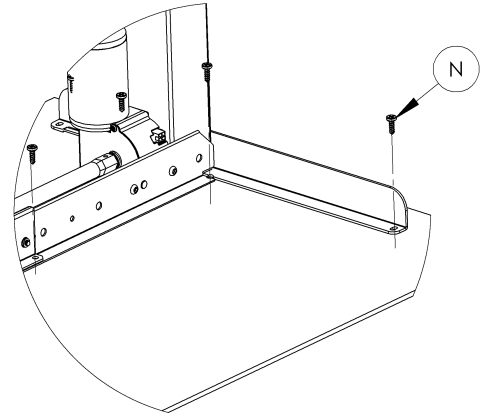
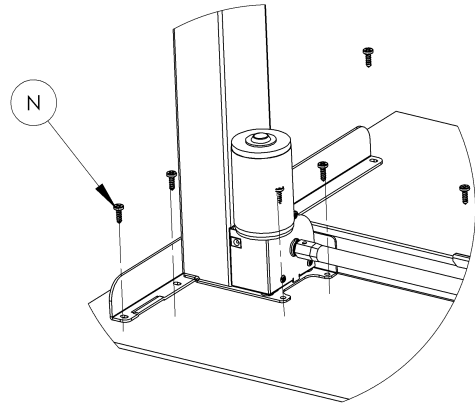
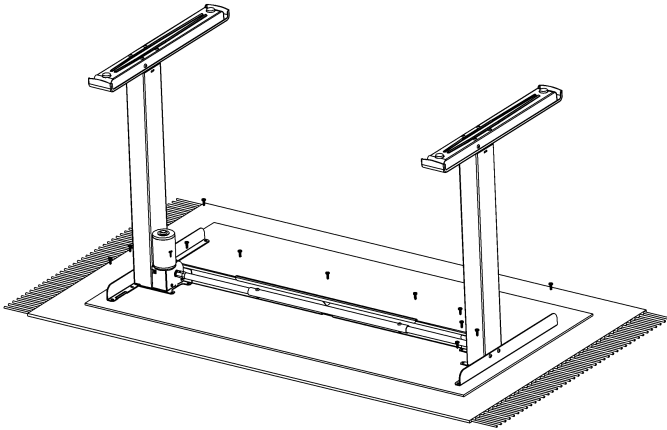

## 8 Mounting of power and control

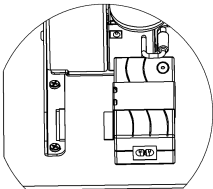
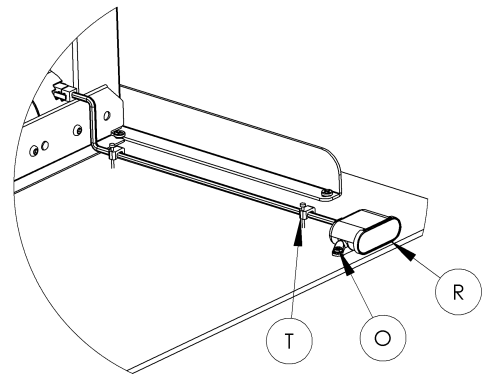
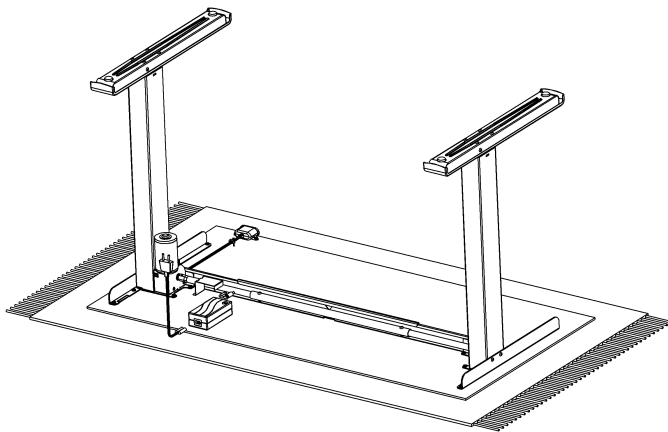

← click

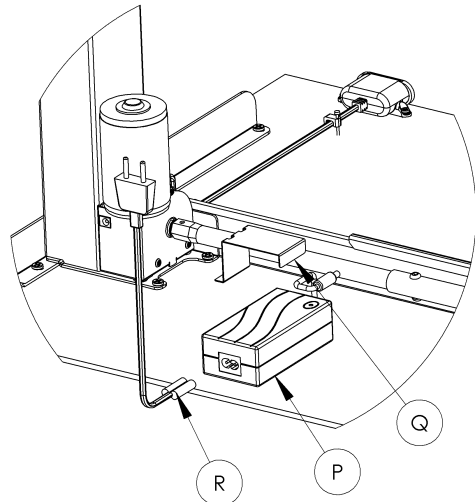
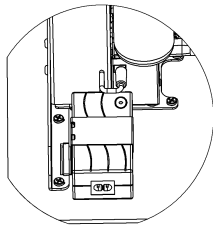
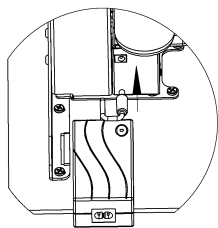

## INHALTSVERZEICHNIS

1. SICHERHEIT UND WICHTIGE HINWEISE
2. VERWENDUNGSRICHTLINIEN
3. AUFBAU UND INSTALLATION
4. BEDIENUNG
5. WARTUNG, REINIGUNG UND MÄNGEL
6. TECHNISCHE DATEN
7. ÜBERSICHT DER BAUTEILE
8. MONTAGEANLEITUNG
9. KONFORMITÄTSERKLÄRUNG

## WICHTIGE INFORMATIONEN !

Es ist absolut notwendig diese Gebrauchs- und Montageanleitung VOR dem Aufbau, der Installation und der Benutzung des Tisches zu lesen. So schützen Sie sich selbst und das Produkt.

### 1. SICHERHEIT UND WICHTIGE HINWEISE

Bitte lesen Sie die vollständige Bedienungsanleitung VOR der ersten Inbetriebnahme.

Sie erhalten wichtige Informationen zur Sicherheit, Verwendung, Installation und Wartung des Tisches. Auf diese Weise schützen Sie sich selbst und vermeiden Schäden des Tisches.

Bitte bewahren Sie diese Bedienungsanleitung auf und geben Sie sie an einen eventuellen neuen Besitzer weiter!

### 2. VERWENDUNGSRICHTLINIEN

- Dieser elektromotorisch höhenverstellbare Tisch ist ausschließlich für trockene innenliegende Arbeitsumgebungen ( 0- 40 °C; 20 - 90 % relative Luftfeuchtigkeit ) bestimmt. Der Tisch ist stufenlos höhenverstellbar, für bestmögliche ergonomische Arbeitsbedingungen.
- Der Tisch wurde nicht für andere Zwecke als die im Handbuch enthaltenen konzipiert, z.B. darf er nicht in Räumen mit hoher Luftfeuchtigkeit oder Nässe, noch zum Heben von Personen verwendet werden. Jede andere Verwendung erfolgt auf eigene Gefahr !
- Nicht unter das Tischgestell kriechen, dort liegen oder sich dort bewegen, und nicht auf dem Tischgestell sitzen oder stehen.
- Kinder dürfen den Tisch nur unter Aufsicht von Erwachsenen benutzen.

Haftung : Der Hersteller übernimmt unter keinen Umständen Haftung für Schäden, die aus fehlerhafter Installation, nicht autorisierter Handhabung oder unsachgemäßem Gebrauch, als die in dieser Bedienungsanleitung beschrieben, verursacht wurden.

### 3. AUFBAU UND INSTALLATION

- Ist der Tisch montiert (siehe Montageanleitung in Kapitel 8), werden die justierbaren Füße so eingestellt, dass der Tisch waagrecht steht und nicht verzogen ist. Danach den Tisch mit dem Netzstecker an den Strom anschließen, somit ist der Tisch einsatzbereit.
- Stellen Sie sicher, dass keine Kabel eingeklemmt werden können.
- Stellen Sie den Tisch in einem sicheren Abstand zu Fenstern, Heizkörpern, Mobiliar usw. auf, so dass der Tisch höhenverstellt werden kann.
- Platzieren Sie keine Gegenstände, die höher als 55 cm/ 21" sind unter dem Tisch.
- Um den Tisch, nachdem er zusammengebaut wurde, zu bewegen, ziehen Sie den Netzstecker und demontieren Sie die Tischplatte, der Tisch darf NIEMALS an der Tischplatte angehoben werden.

### 4. BEDIENUNG

Bedienung der Höhenverstellung:

Drücken Sie die Knöpfe zum Hinauf- oder Herunterfahren

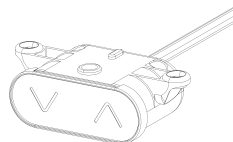

WARNUNG : EINE MISSACHTUNG DER MONTAGE-, SICHERHEITS- UND BEDIENUNGSANLEITUNG DIESES PRODUKTES KANN ZU SCHWEREN KÖRPERLICHEN VERLETZUNGEN FÜHREN.



## 5. WARTUNG, REINIGUNG UND MÄNGEL

- Der Tisch benötigt keine besondere Wartung, wie in Kapitel 2 der Gebrauchsanweisung beschrieben.
- Bitte verwenden Sie zur Reinigung des Tisches nur ein nebelfeuchtes Tuch.
- Bitte wenden Sie sich an Ihren Händler, falls beim Tisch ungewöhnliche Geräusche auftreten.

## 6. TECHNISCHE DATEN

<b>Rahmen, Materialien</b>	Stahl, pulverbeschichtet
<b>Gewicht</b>	17 kg (gestell)
<b>Breite</b>	Bis zu 180 cm
<b>Tiefe</b>	Bis zu 18 cm
<b>Höhe</b>	68 - 118 cm
<b>Max. Belastbarkeit</b>	50 kg auf der Tischplatte
<b>Geschwindigkeit</b>	25 mm/sek
<b>Einschlatdauer</b>	10% von 50% der Belastung auf dem Tisch oder max. 2 Min. unterbrochen
<b>Betrieb</b>	Mikroschalter
<b>Stromspannung</b>	100-240 VAC   50/60 Hz
<b>Standby-Verbrauch</b>	< 0,15 Watt

## 7. ÜBERSICHT DER BAUTEILE

Siehe Seite 20.

## 8. MONTAGEANLEITUNG

Siehe Seite 19 - 22.

## 9. KONFORMITÄTSERKLÄRUNG

Wir erklären hiermit unter alleiniger Verantwortung, dass folgende Produkte:

- Steh- und Sitztisch Model HeighTivity

auf die sich die Erklärung bezieht, in Übereinstimmung ist mit folgenden Richtlinien und normativen Dokumenten:

- Der Richtlinie 2006/42/EG des Europäischen Parlaments und des Rates vom 17. Mai 2006 über Maschinen und der Änderung der Richtlinie 95/16/EG (Neufassung)

In Bezug auf oben stehendes beachten Sie bitte, dass:

- Steh-Sitztische als eine Maschine betrachtet werden und
- Steh-Sitztische nicht verwendet werden dürfen, bevor er nach den Vorschriften dieser Gebrauchs / Montageanleitung komplett zusammgebaut und installiert wurde.

### Hersteller

HeighTivity by ConSet A/S | Industrivej 23 | 6900 Skjern | Denmark

www.heightivity.com | Tlf.: +45 96800080 | info@heightivity.com

## 7. Bauteile

Ⓐ Center travers

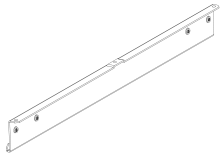

x1

Ⓑ Side travers

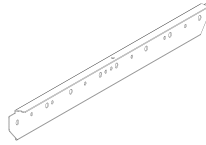

x2

Ⓒ Center tube

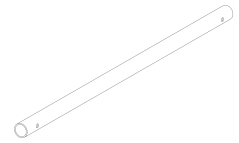

x1

Ⓓ Non-motor leg tube

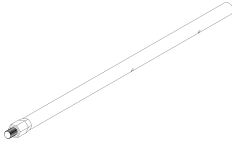

x1

Ⓔ Motor leg tube

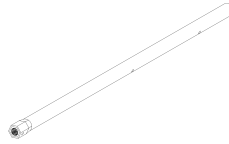

x1

Ⓕ Motor leg

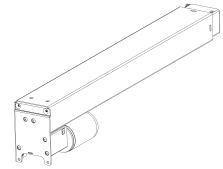

x1

Ⓖ Non-motor leg

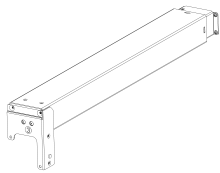

x1

Ⓗ Tabletop bracket L

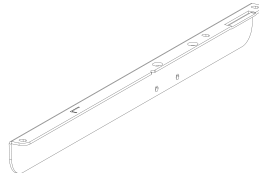

x1

Ⓘ Tabletop bracket R

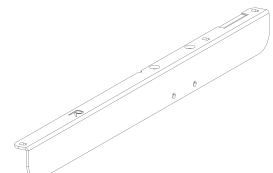

x1

Ⓙ Fuss

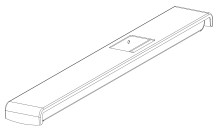

x2

Ⓚ M5x8mm

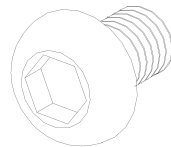

x28

Ⓛ M5x8mm

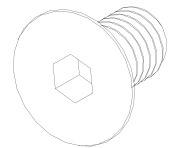

x4

Ⓜ Glide M6x20

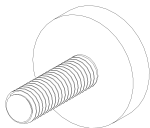

x4

Ⓝ Screw 5x16mm



x15

Ⓞ Screw 3x16mm

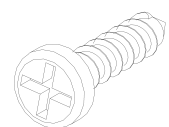

x2

Ⓟ Netzteil

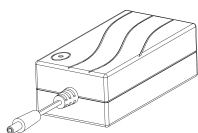

x1

Ⓠ Power supply bracket

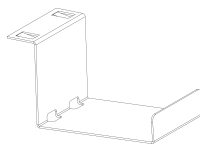

x1

Ⓡ Netzkabel

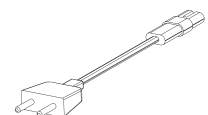

x1

Ⓢ Bedienelement

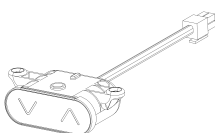

x1

Ⓣ Drahtstift

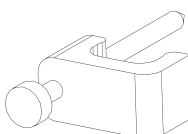

x2

## 8. Montageanleitung

### 1 Adjusting travers

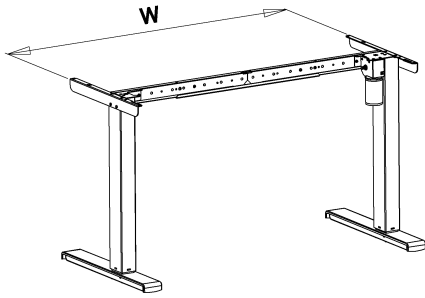

W, cm	W, inch		X, cm	X, inch
112cm	44 1/8"		111cm	43 3/4"
127cm	50"		126cm	49 5/8"
142cm	55 7/8"		141cm	55 1/2"

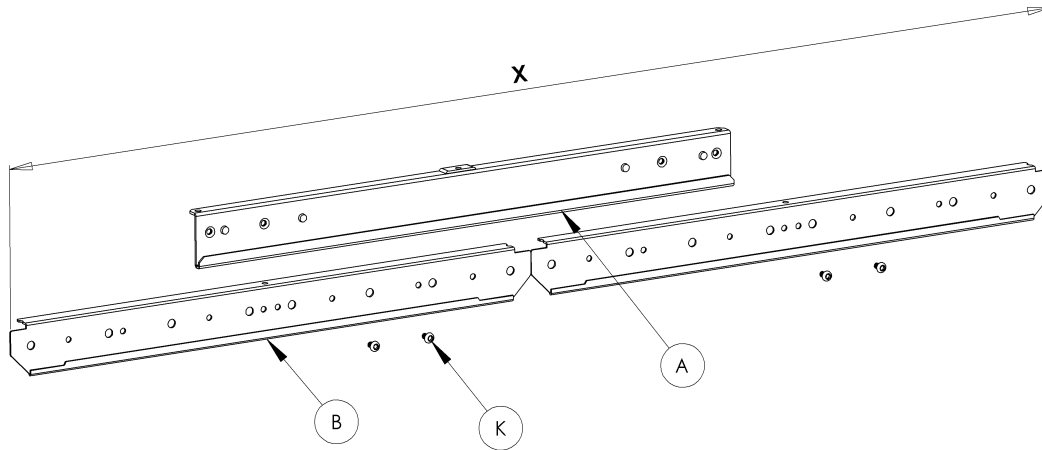

### 2 Adjusting carrier tube

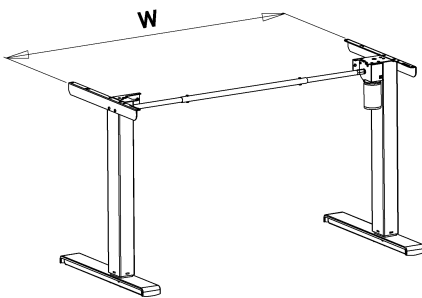

W, cm	W, inch		Y, cm	Y, inch
112cm	44 1/8"		97cm	38 1/4"
127cm	50"		112cm	44 1/8"
142cm	55 7/8"		127cm	50"

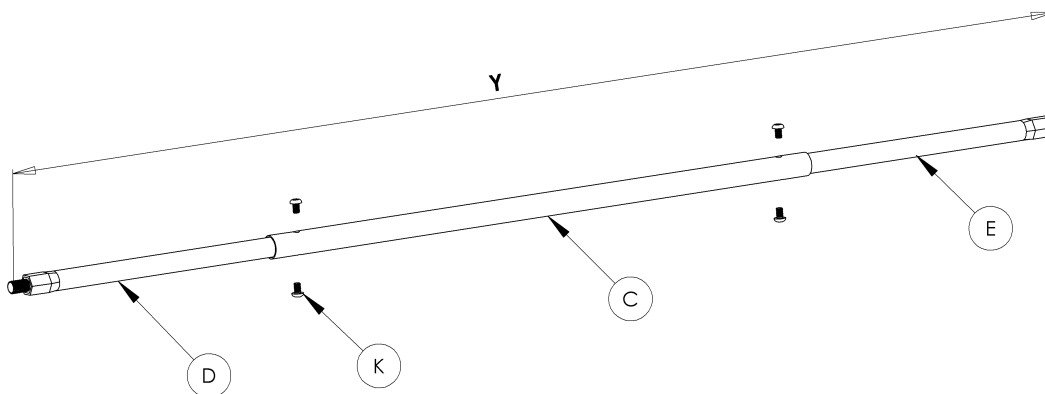
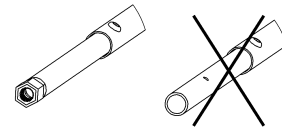

**3** Mounting of topbrackets

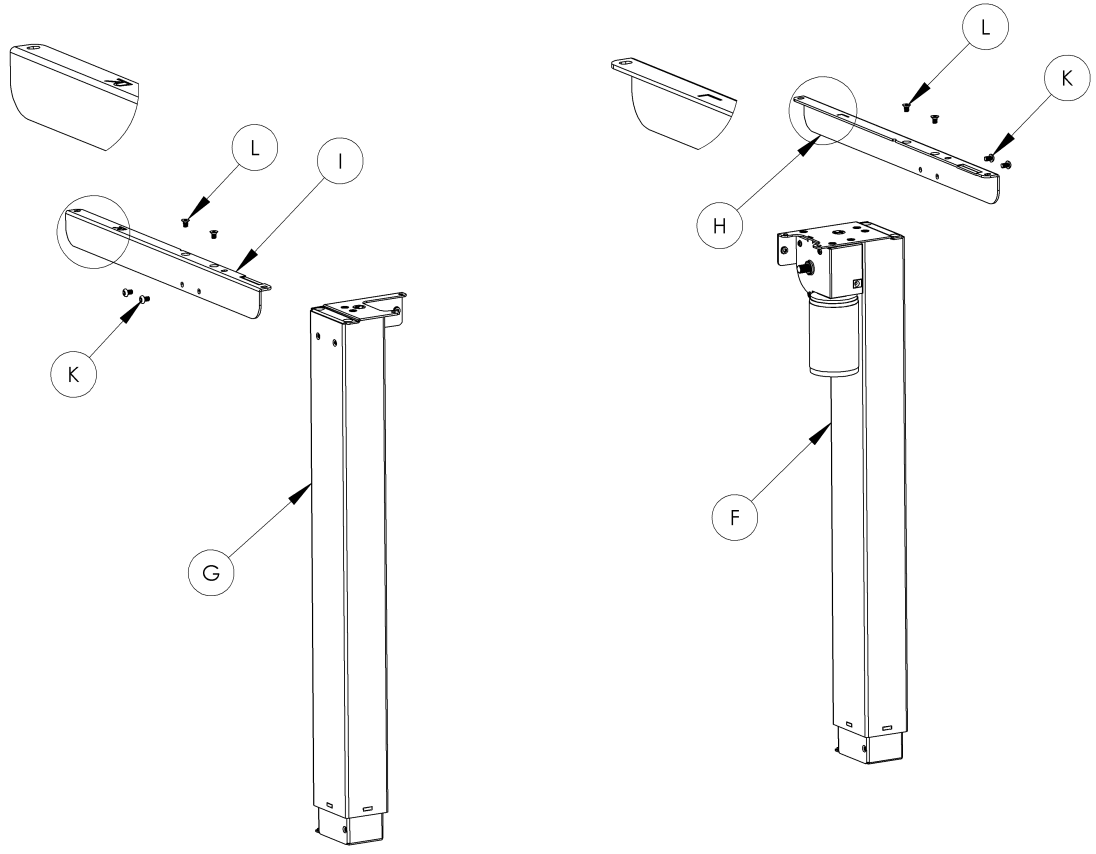

**4** Mounting of Non-motor leg

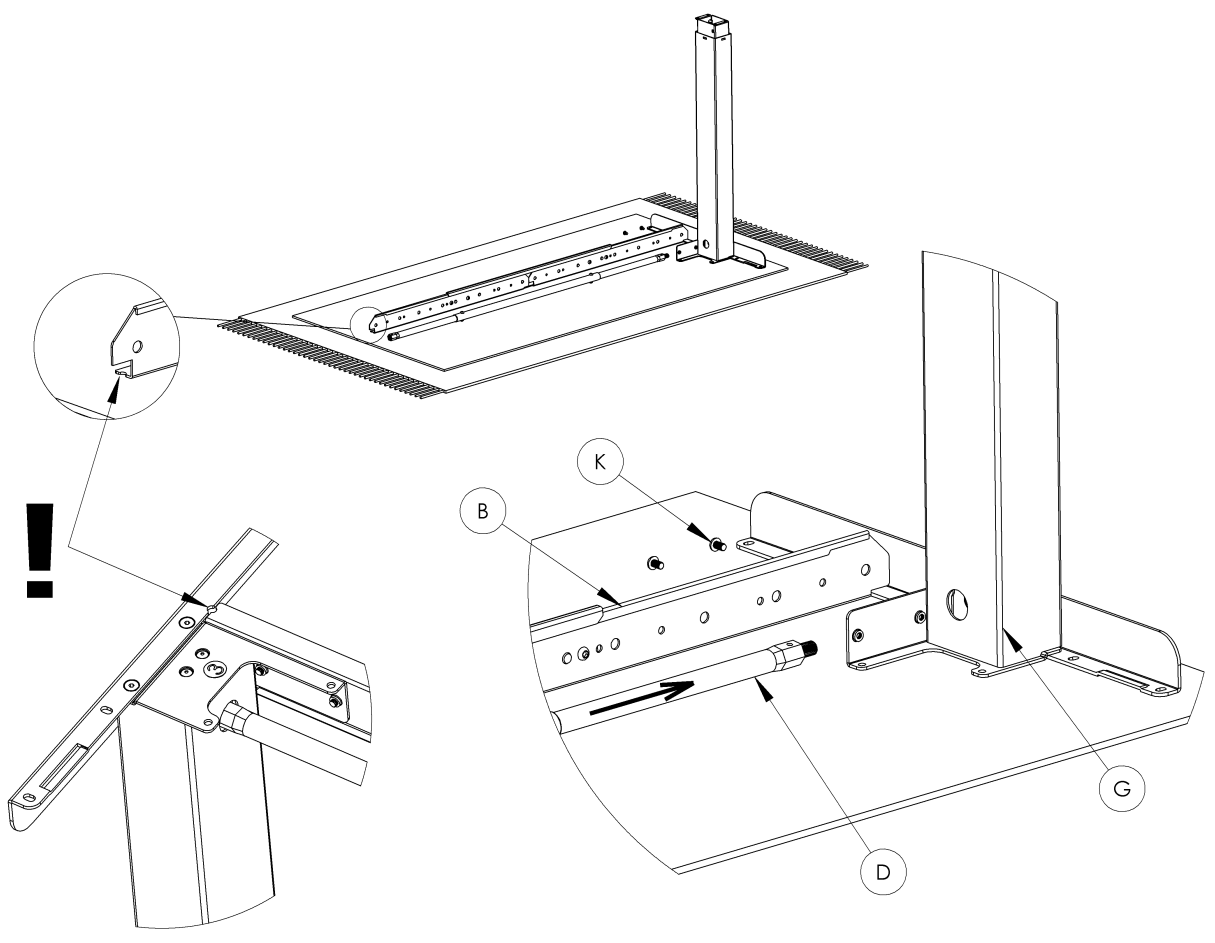

**5** Mounting of Motor leg

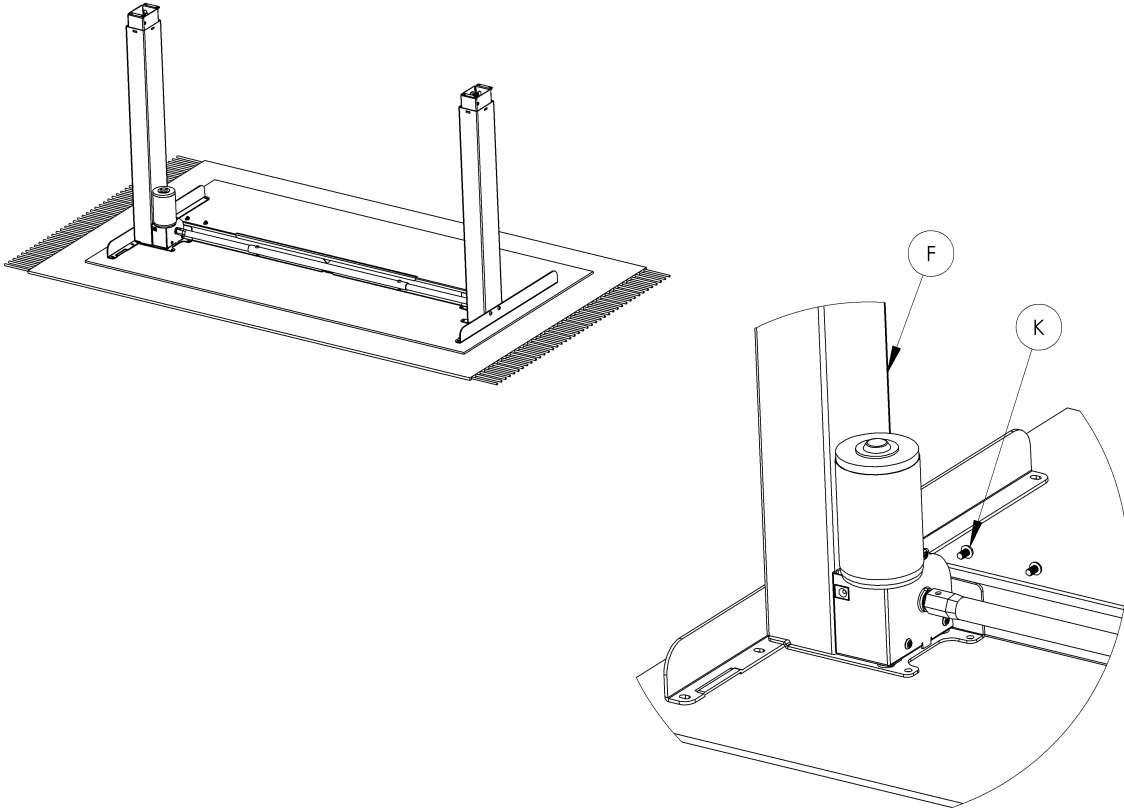

**6** Mounting of feet

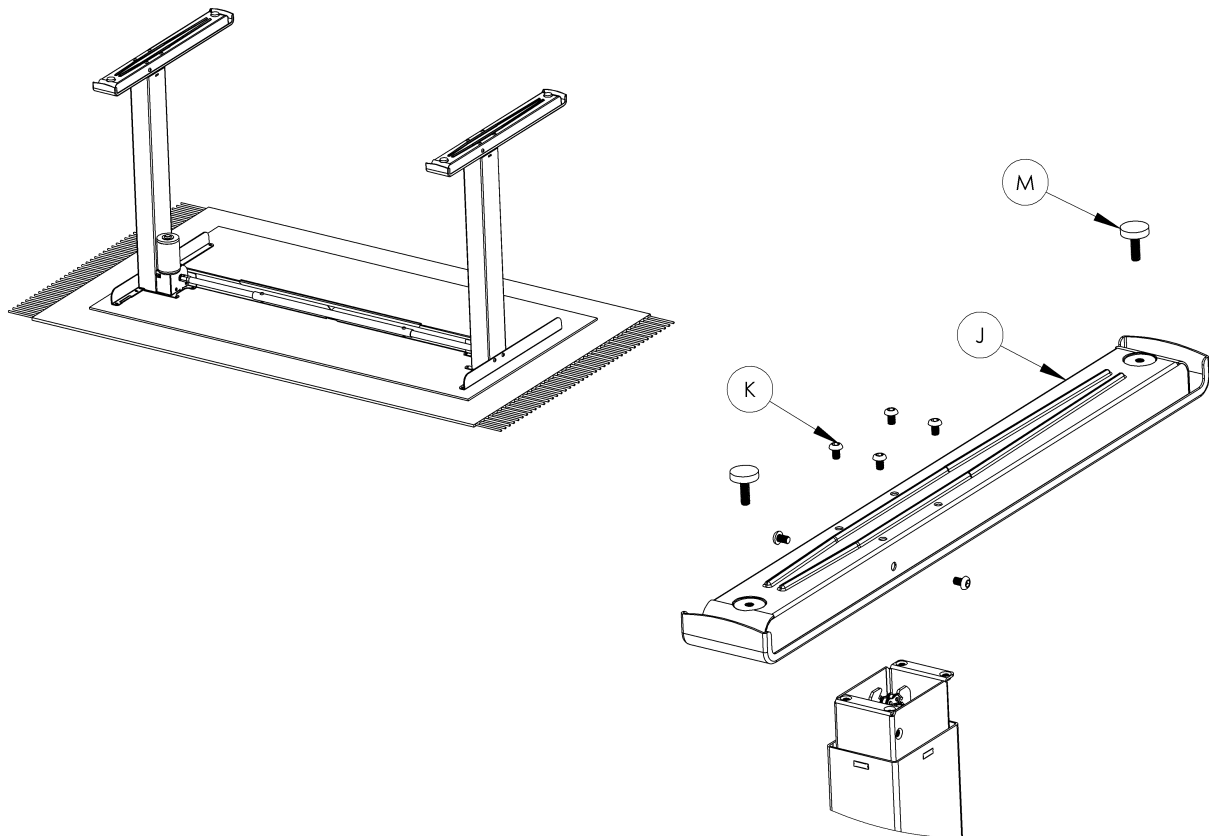

## 7 Mounting of tabletop

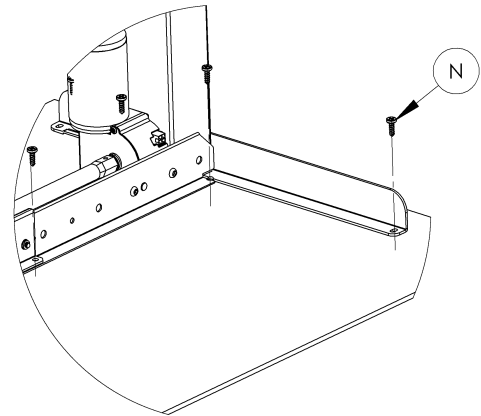
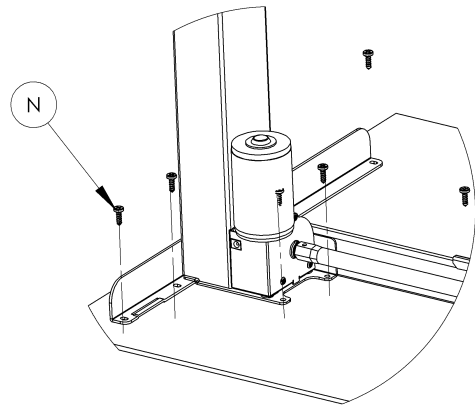
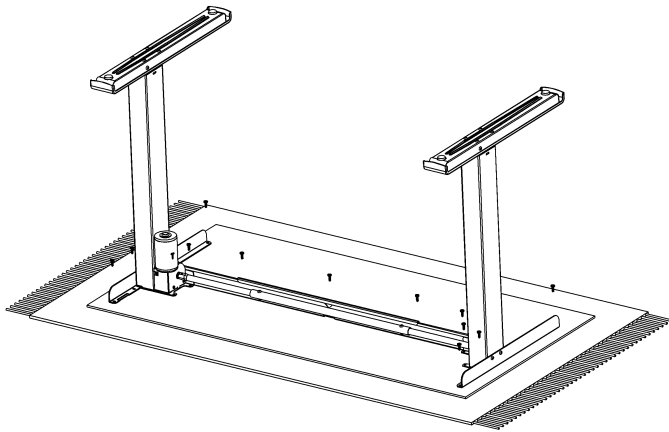

## 8 Mounting of power and control

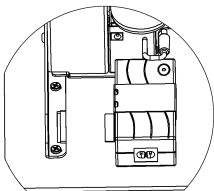
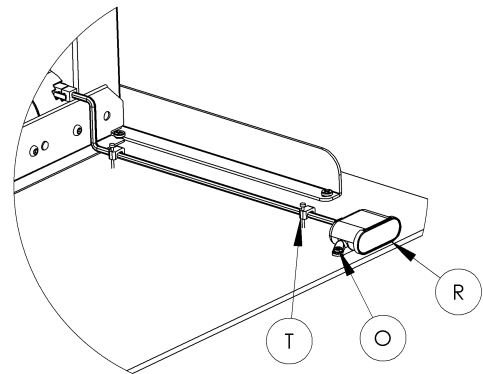
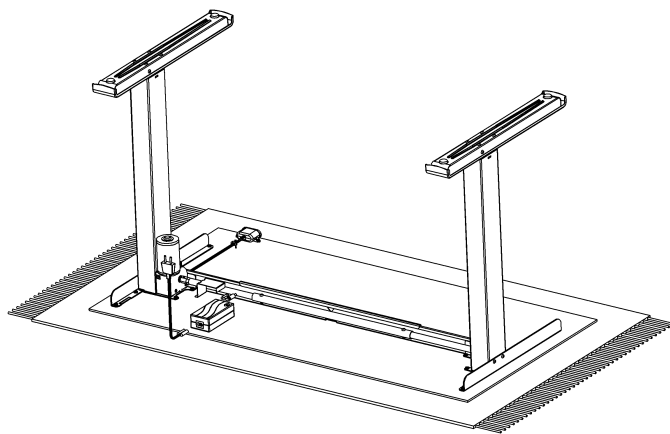

← *click*

